

4.1 Activity READ

The bulk power flow data input activity, READ, picks up hand-typed power flow source data and enters it into the load flow working case, rearranging it from its original format into a computationally oriented data structure in the process. The source data records may be input from a Power Flow Raw Data File (the normal case) or from the dialog input device (console keyboard or Response File).

All data is read in "free format" with data items separated by a comma or one or more blanks. Each category of data, except the case identification data, is terminated by a record specifying an "I" value of zero.

Activity READ is not sensitive to any interrupt control code options.

4.1.1 Power Flow Raw Data File Contents

The input stream to activity READ consists of 16 groups of records, with each group containing a particular type of data required in power flow work (see [Figure 4-1](#)).

For data records described in [Sections 4.1.1.3 through 4.1.1.9, 4.1.1.11, 4.1.1.12, and 4.1.1.16](#), those data items that designate ac buses may be specified as either extended bus names enclosed in single quotes or bus numbers when the suffix NAME is specified when selecting activity READ (see [Section 4.1.2](#)).

4.1.1.1 Case Identification Data

Case identification data consists of three data records. The first record contains two items of data as follows:

IC, SBASE

where:

IC Change code:
 0 - base case
 1 - add data to the working case
 IC = 0 by default.

SBASE System base MVA. SBASE = 100. by default.

The next two records each contain a line of heading to be associated with the case. Each line may contain up to 60 characters, which are typed in columns 1 through 60.

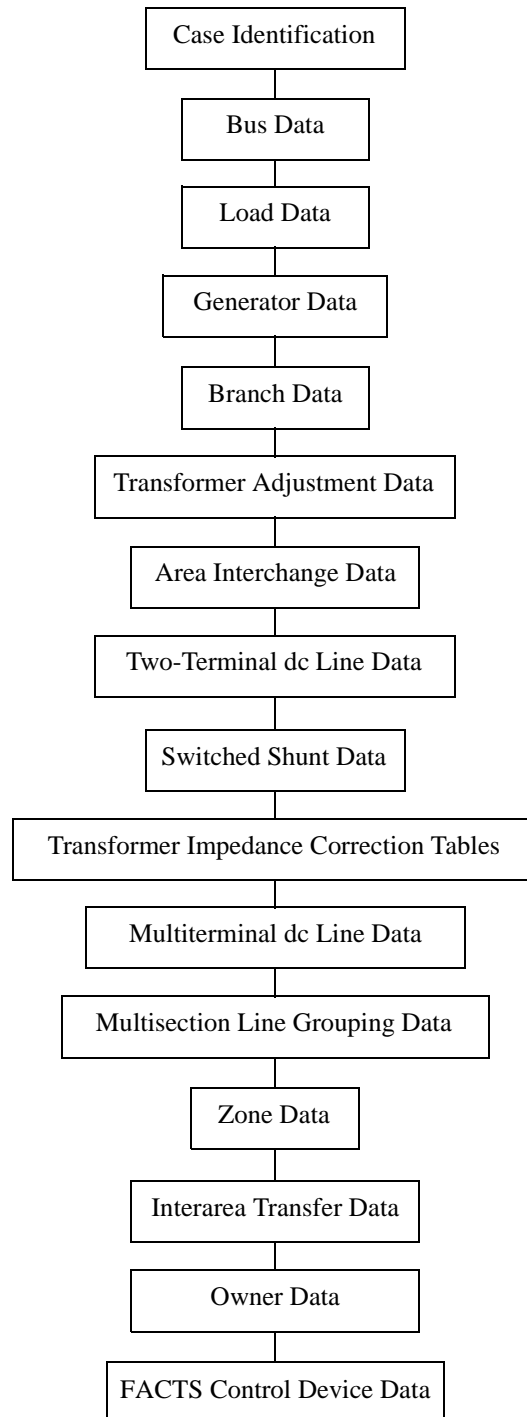

Figure 4-1. Power Flow Raw Data Input Structure

4.1.1.2 Bus Data

Each network bus to be represented in PSS/E is introduced by reading a bus data record. Each bus data record has the following format:

```
I, 'NAME', BASKV, IDE, GL, BL, AREA, ZONE, VM, VA, OWNER
```

where:

I	Bus number (1 to 99997).
NAME	Alphanumeric identifier assigned to bus "I". The name may be up to eight characters and must be enclosed in single quotes. NAME may contain any combination of blanks, uppercase letters, numbers and special characters, but the first character must not be a minus sign. NAME is eight blanks by default.
BASKV	Bus base voltage; entered in kV. BASKV = 0. by default.
IDE	Bus type code: 1 - load bus (no generation) 2 - generator or plant bus (either voltage regulating or fixed Mvar) 3 - swing bus 4 - disconnected (isolated) bus IDE = 1 by default.
GL	Real component of shunt admittance to ground; entered in MW at one per unit voltage. GL should not include any resistive impedance load, which is entered as part of load data. GL = 0. by default.
BL	Reactive component of shunt admittance to ground; entered in Mvar at one per unit voltage. BL should not include any reactive impedance load, which is entered as part of load data, or line charging and line connected shunts, which are entered as part of branch data. BL is positive for a capacitor, and negative for a reactor or an inductive load. BL = 0. by default.
AREA	Area number. AREA = 1 by default.
ZONE	Zone number. ZONE = 1 by default.
VM	Bus voltage magnitude; entered in pu. VM = 1. by default.
VA	Bus voltage phase angle; entered in degrees. VA = 0. by default.
OWNER	Owner number. OWNER = 1 by default.

VM and VA need to be set to their actual solved case values only when the network, as entered into the working case via activity READ, is to be considered solved as read in. Otherwise, they may be set to their default values.

Bus data input is terminated with a record specifying a bus number of zero.

4.1.1.3 Load Data

Each network bus at which load is to be represented must be specified in at least one load data record. Each load data record has the following format:

I, ID, STATUS, AREA, ZONE, PL, QL, IP, IQ, YP, YQ, OWNER

where:

I	Bus number (1 to 99997), or extended bus name enclosed in single quotes (see Section 4.1.2).
ID	Two-character uppercase nonblank alphanumeric load identifier used to distinguish among multiple loads at bus "I". It is <i>strongly</i> recommended that, at buses for which a single load is present, the load be designated as having the load identifier '1'. ID = '1' by default.
STATUS	Initial load status of one for in-service and zero for out-of-service. STATUS = 1 by default.
AREA	Area to which the load is assigned. By default, AREA is the area to which bus "I" is assigned (see Section 4.1.1.2).
ZONE	Zone to which the load is assigned. By default, ZONE is the zone to which bus "I" is assigned (see Section 4.1.1.2).
PL	Real power component of constant MVA load; entered in MW. PL = 0. by default.
QL	Reactive power component of constant MVA load; entered in Mvar. QL = 0. by default.
IP	Real power component of constant current load; entered in MW at one per unit voltage. IP = 0. by default.
IQ	Reactive power component of constant current load; entered in Mvar at one per unit voltage. IQ = 0. by default.
YP	Real power component of constant admittance load; entered in MW at one per unit voltage. YP = 0. by default.
YQ	Reactive power component of constant admittance load; entered in Mvar at one per unit voltage. YQ is a negative quantity for an inductive load. YQ = 0. by default.
OWNER	Owner to which the load is assigned. By default, OWNER is the owner to which bus "I" is assigned (see Section 4.1.1.2).

Multiple loads may be represented at a bus by specifying more than one load data record for the bus, each with a different load identifier. The area, zone, and owner assignments of loads are used for area, zone, and owner totaling purposes (e.g., in activities [AREA](#), [ZONE](#), and [OWNER](#)) and for load scaling and conversion purposes. They may differ from those of the bus to which they are connected. The area and zone assignments of loads may optionally be used during area and zone interchange calculations (see [Section 4.10.3.3](#), and [Sections 4.46](#) through [4.51](#)).

Further details on load characteristic modeling is given in [Sections 4.8.3, 4.16, and 4.17](#).

Load data input is terminated with a record specifying a bus number of zero.

4.1.1.4 Generator Data

Each network bus to be represented as a generator or plant bus in PSS/E must be specified in a generator data record. In particular, each bus specified in the bus data input with a type code of two or three **must** have a generator data record entered for it. Each generator data record has the following format:

```
I , ID , PG , QG , QT , QB , VS , IREG , MBASE , ZR , ZX , RT , XT , GTAP , STAT , RMPCT , PT , PB , O1 , F1 , . . . , O4 , F4
```

where:

I	Bus number (1 to 99997), or extended bus name enclosed in single quotes (see Section 4.1.2).
ID	Two-character uppercase nonblank alphanumeric machine identifier used to distinguish among multiple machines at bus "I". It is strongly recommended that, at buses for which a single machine is present, the machine be designated as having the machine identifier '1'. ID = '1' by default.
PG	Generator real power output; entered in MW. PG = 0. by default.
QG	Generator reactive power output; entered in Mvar. QG need be entered only if the case, as read in, is to be treated as a solved case. QG = 0. by default.
QT	Maximum generator reactive power output; entered in Mvar. For fixed output generators (i.e., nonregulating), QT must be equal to the fixed Mvar output. QT = 9999. by default.
QB	Minimum generator reactive power output; entered in Mvar. For fixed output generators, QB must be equal to the fixed Mvar output. QB = -9999. by default.
VS	Regulated voltage setpoint; entered in pu. VS = 1. by default.
IREG	Bus number, or extended bus name enclosed in single quotes (see Section 4.1.2), of a remote <i>type one</i> bus whose voltage is to be regulated by this plant to the value specified by VS. If the type code of bus IREG is other than one, bus I regulates its own voltage to the value specified by VS. IREG is entered as zero if the plant is to regulate its own voltage and must be zero for a type three (swing) bus. IREG = 0 by default.
MBASE	Total MVA base of the units represented by this machine; entered in MVA. This quantity is not needed in normal power flow and equivalent construction work, but is required for switching studies, fault analysis, and dynamic simulation. MBASE = system base MVA by default.
ZR,ZX	Machine impedance, ZSORCE; entered in pu on MBASE base. This data is not needed in normal load flow and equivalent construction work, but is required for

	switching studies, fault analysis, and dynamic simulation. For dynamic simulation, this complex impedance must be set equal to the subtransient impedance for those generators to be modeled by subtransient level machine models, and to transient impedance for those to be modeled by classical or transient level models. ZR = 0. and ZX = 1. by default.
RT,XT	Step-up transformer impedance, XTRAN; entered in pu on MBASE base. RT + jXT = 0. by default.
GTAP	Step-up transformer off-nominal turns ratio; entered in pu. GTAP = 1. by default.
STAT	Initial machine status of one for in-service and zero for out-of-service; STAT = 1 by default.
RMPCT	Percent of the total Mvar required to hold the voltage at bus IREG that are to be contributed by the generation at bus I; RMPCT must be positive. RMPCT is needed only if IREG specifies a remote type one bus and there is more than one generator bus controlling the voltage at bus IREG. RMPCT = 100. by default.
PT	Maximum generator real power output; entered in MW. PT = 9999. by default.
PB	Minimum generator real power output; entered in MW. PB = -9999. by default.
Oi	Owner number; each machine may have up to four owners. By default, O1 is the owner to which bus "I" is assigned (see Section 4.1.1.2) and O2, O3, and O4 are zero.
Fi	Fraction of total ownership assigned to owner Oi; each Fi must be positive. The Fi values are normalized such that they sum to 1.0 before they are placed in the working case. By default, each Fi is 1.0.

In specifying reactive power limits, the use of very narrow var limit bands is discouraged. The Newton-Raphson based power flow solutions require that the difference between the plant high and low Mvar limits be greater than 0.002 pu at all type two buses with unequal Mvar limits (0.2 Mvar on a 100 MVA system base). It is recommended that machines with unequal Mvar limits have Mvar ranges substantially wider than this minimum permissible range.

When two or more machines are to be separately modeled at a plant, their data may be introduced into the working case using one of two approaches.

A generator data record may be entered in activities READ, **TREA**, or **RDCH** for each of the machines to be represented, with machine powers, power limits, impedance data, and step-up transformer data for each machine specified on separate generator data records. The plant power output and power limits are taken as the sum of the corresponding quantities of the in-service machines at the plant. The values specified for VS, IREG, and RMPCT, which are treated as plant quantities rather than individual machine quantities, must be identical on each of these generator data records.

Alternatively, a single generator record may be specified in activities READ, **TREA**, or **RDCH** with the plant total power output, power limits, voltage setpoint, remotely regulated bus, and percent of contributed Mvar entered. Impedance and step-up transformer data may be omitted. The PSS/E

power flow activities may be used and then, any time prior to beginning switching study, fault analysis, or dynamic simulation work, activity **MCRE** may be used to introduce the individual machine impedance and step-up transformer data; activity **MCRE** also apportions the total plant loading among the individual machines (see [Section 4.4](#)).

Generator data input is terminated with a record specifying a bus number of zero.

4.1.1.5 Branch Data

Each ac network branch to be represented in PSS/E is introduced by reading a branch data record. Each branch data record has the following format:

```
I , J , CKT , R , X , B , RATEA , RATEB , RATEC , RATIO , ANGLE , GI , BI , GJ , BJ , ST , LEN , O1 , F1 , . . . , O4 , F4
```

where:

- | | |
|-------|--|
| I | Branch " <i>from bus</i> " number, or extended bus name enclosed in single quotes (see Section 4.1.2). For a transformer, this bus is the tapped side bus. |
| J | Branch " <i>to bus</i> " number, or extended bus name enclosed in single quotes (see Section 4.1.2). For a transformer, this bus is the impedance side bus. J is entered as a negative number, or with a minus sign before the first character of the extended bus name, to designate it as the metered end; otherwise, bus I is assumed to be the metered end. |
| CKT | Two-character uppercase nonblank alphanumeric branch circuit identifier; the first character of CKT must not be an ampersand ("&"); see Section 4.1.1.12 . It is <i>strongly</i> recommended that single circuit branches be designated as having the circuit identifier '1'. CKT = '1' by default. |
| R | Branch resistance; entered in pu. A value of R must be entered for each branch. |
| X | Branch reactance; entered in pu. A nonzero value of X must be entered for each branch. See Section 4.1.4 for details on the treatment of branches as zero impedance lines. |
| B | Total branch charging susceptance; entered in pu. B = 0. by default. |
| RATEA | First current rating; entered in MVA. RATEA = 0. (bypass check for this branch) by default. See also Section 4.53 . |
| RATEB | Second current rating; entered in MVA. RATEB = 0. by default. |
| RATEC | Third current rating; entered in MVA. RATEC = 0. by default. |
| RATIO | Transformer off-nominal turns ratio; entered in pu. RATIO is entered as zero if the branch is not a transformer. RATIO = 0. by default. |
| ANGLE | Transformer phase shift angle; entered in degrees. Ignored unless RATIO is entered as a nonzero value. ANGLE is positive for a positive phase shift from the untapped to the tapped side. ANGLE = 0. by default. |

GI,BI	Complex admittance of the line shunt at the bus "I" end of the branch; entered in pu. BI is negative for a line connected reactor. $GI + jBI = 0$. by default.
GJ,BJ	Complex admittance of the line shunt at the bus "J" end of the branch; entered in pu. BJ is negative for a line connected reactor. $GJ + jBJ = 0$. by default.
ST	Initial branch status where 1 designates in-service and 0 designates out-of-service. $ST = 1$ by default.
LEN	Line length; entered in user-selected units. $LEN = 0$. by default.
O _i	Owner number; each branch may have up to four owners. By default, O ₁ is the owner to which bus "I" is assigned (see Section 4.1.1.2) and O ₂ , O ₃ , and O ₄ are zero.
F _i	Fraction of total ownership assigned to owner O _i ; each F _i must be positive. The F _i values are normalized such that they sum to 1.0 before they are placed in the working case. By default, each F _i is 1.0.

Branch data input is terminated with a record specifying a "*from bus*" number of zero.

4.1.1.6 Transformer Adjustment Data

Control parameters for the automatic adjustment of transformers and phase shifters are specified in the transformer adjustment data records. Only branches designated as transformers (i.e., branches input with a nonzero value of RATIO), may be specified in a transformer adjustment data record. All transformers are adjustable and the control parameters may be specified either at the time of raw data input or subsequently via activities [CHNG](#) or [XLIS](#), or the data editor windows. Any transformer for which no control data is provided has default data assigned to it; the default data is such that the transformer is treated as a fixed tap transformer.

Each transformer adjustment data record has the following format:

I , J , CKT , ICONT , RMA , RMI , VMA , VMI , STEP , TABLE , CNTRL , CR , CX

where:

I	"From bus" number, or extended bus name enclosed in single quotes (see Section 4.1.2).
J	"To bus" number, or extended bus name enclosed in single quotes (see Section 4.1.2).
CKT	Circuit identifier; the branch described by I, J, and CKT must have previously been introduced into PSS/E with a nonzero value of RATIO specified.
ICONT	Bus number, or extended bus name enclosed in single quotes (see Section 4.1.2), of the bus whose voltage is to be controlled by the transformer turns ratio adjustment option of the power flow solution activities. ICONT should be nonzero only for voltage controlling transformers.

ICONT may specify a bus other than I and J; in this case, the sign of ICONT defines the location of the controlled bus relative to the transformer. If ICONT is entered as a positive number, or a quoted extended bus name, the ratio is adjusted as if bus ICONT is on the untapped (impedance) side of the transformer; if ICONT is entered as a negative number, or a quoted extended bus name with a minus sign preceding the first character, the ratio is adjusted as if bus |ICONT| is on the tapped side of the transformer. ICONT = 0 by default.

- RMA Upper limit of either:
- Off-nominal ratio for voltage or Mvar controlling transformers, entered in pu.
 - Phase shift angle for MW controlling transformers, entered in degrees.
- RMA = 1.5 by default.
- RMI Lower limit of either:
- Off-nominal ratio for voltage or Mvar controlling transformers, entered in pu.
 - Phase shift angle for MW controlling transformers, entered in degrees.
- RMI = 0.51 by default.
- VMA Upper limit of either:
- Controlled bus voltage, entered in pu.
 - Real power flow through the phase shifter, calculated at the tapped side bus, entered in MW.
 - Reactive power flow through the transformer, calculated at the tapped side bus, entered in Mvar.
- VMA = 1.5 by default.
- VMI Lower limit of either:
- Controlled bus voltage, entered in pu.
 - Real power flow through the phase shifter, calculated at the tapped side bus, entered in MW.
 - Reactive power flow through the transformer, calculated at the tapped side bus, entered in Mvar.
- VMI = 0.51 by default.
- STEP Transformer turns ratio step increment; ignored for phase shifters controlling real power flow. STEP = 0.00625 by default.
- TABLE Zero, or the number of a transformer impedance correction table if this transformer's impedance is to be a function of either off-nominal turns ratio or phase shift angle (see [Section 4.1.1.10](#)). TABLE = 0 by default.

CNTRL Adjustment enable flag; one to enable automatic adjustment by this transformer as specified by its adjustment data values when that adjustment is activated during power flow solutions; zero to prohibit the automatic adjustment of this transformer. CNTRL = 1 by default.

CR, CX Load drop compensation impedance for voltage controlling transformers, entered in pu; ignored for MW and Mvar flow controlling transformers. $CR + jCX = 0$. by default.

Table 4-2 summarizes the interpretation of these data items when they are used by the automatic adjustment options of the power flow solution activities. See **Section 4.10.3** for further discussion.

Transformer adjustment data input is terminated with a record specifying a "from bus" number of zero.

Table 4-2. Transformer Adjustment Data

	ICONT	RMA, RMI	RMA-RMI	VMA, VMI	VMA-VMI	STEP	CR, CX
Discrete ratio/voltage	Controlled bus	Ratio limits	≤ 0.9 > 0 .	Voltage limits	≤ 0.9 > 0 .	> 0 .	Compensating impedance
Direct ratio/voltage	Controlled bus	Ratio limits	≤ 0.9 > 0 .	Voltage limits	≤ 0.9 > 0 .	≥ 0 .	Compensating impedance
Direct ratio/Mvar	Ignored	Ratio limits	≤ 0.9 > 0 .	Mvar limits	> 1.0	≥ 0 .	Ignored
Direct angle/MW	Ignored	Angle limits	> 1.0	MW limits	> 0.0	Ignored	Ignored

4.1.1.7 Area Interchange Data

Area identifiers and interchange control parameters are specified in area interchange data records. Data for each interchange area may be specified either at the time of raw data input or subsequently via activities **CHNG** or **XLIS**, or the data editor windows. Each area interchange data record has the following format:

I, ISW, PDES, PTOL, 'ARNAME'

where:

I Area number.

ISW Bus number, or extended bus name enclosed in single quotes (see **Section 4.1.2**), of the area slack bus for area interchange control. The bus **must** be a generator (type two) bus in the specified area. Any area containing a system swing bus (type three) **must have** either that swing bus or a bus number of zero specified for its area slack bus number. Any area with an area slack bus number of zero is considered a "floating area" by the area interchange control option of the power flow solution activities. ISW = 0 by default.

- PDES** Desired net interchange leaving the area (export); entered in MW. PDES must be specified such that is consistent with the area interchange definition implied by the area interchange control code (tie lines only, or tie lines and loads) to be specified during power flow solutions (see [Sections 4.10.3](#) and [4.10.3.3](#)). PDES = 0. by default.
- PTOL** Interchange tolerance bandwidth; entered in MW. PTOL = 10. by default.
- ARNAME** Alphanumeric identifier assigned to area I. The name may contain up to eight characters and **must** be enclosed in single quotes. ARNAME may be any combination of blanks, uppercase letters, numbers, and special characters. ARNAME is set to eight blanks by default.

Refer to [Section 4.10.3.3](#) for further discussion on the area interchange control option of the power flow solution activities.

Area interchange data input is terminated with a record specifying an area number of zero.

4.1.1.8 Two-Terminal dc Transmission Line Data

Each two-terminal dc transmission line to be represented in PSS/E is introduced by reading three consecutive data records. Each set of dc line data records has the following format:

```

I , MDC , RDC , SETVL , VSCHD , VCMOD , RCOMP , DELTI , METER , DCVMIN , CCCITMX , CCCACC
IPR , NBR , ALFMX , ALFMN , RCR , XCR , EBASR , TRR , TAPR , TMXR , TMNR , STPR , ICR , IFR , ITR , IDR , XCAPR
IPI , NBI , GAMMX , GAMMN , RCI , XCI , EBASI , TRI , TAPI , TMXI , TMNI , STPI , ICI , IFI , ITI , IDI , XCAPI
  
```

The first of the three dc line data records defines the following line quantities and control parameters:

- I** The dc line number.
- MDC** Control mode: 0 for blocked, 1 for power, 2 for current. MDC = 0 by default.
- RDC** The dc line resistance; entered in ohms. No default allowed.
- SETVL** Current (amps) or power (MW) demand. When MDC is one, a positive value of SETVL specifies desired power at the rectifier and a negative value specifies desired inverter power. No default allowed.
- VSCHD** Scheduled compounded dc voltage; entered in kV. No default allowed.
- VCMOD** Mode switch dc voltage; entered in kV. When the inverter dc voltage falls below this value and the line is in power control mode (i.e., MDC = 1), the line switches to current control mode with a desired current corresponding to the desired power at scheduled dc voltage. VCMOD = 0. by default.
- RCOMP** Compounding resistance; entered in ohms. Gamma and/or TAPI is used to attempt to hold the compounded voltage (VDCI + DCCUR*RCOMP) at VSCHD. To control the inverter end dc voltage VDCI, set RCOMP to zero; to control the rectifier end dc voltage VDCR, set RCOMP to the dc line resistance, RDC; otherwise, set RCOMP to the appropriate fraction of RDC. RCOMP = 0. by default.

DELTI	Margin entered in per unit of desired dc power or current. This is the fraction by which the order is reduced when ALPHA is at its minimum and the inverter is controlling the line current. DELTI = 0. by default.
METER	Metered end code of either 'R' (for rectifier) or 'I' (for inverter). METER = 'I' by default.
DCVMIN	Minimum compounded dc voltage; entered in kV. Only used in constant gamma operation (i.e., when GAMMX = GAMMN) when TAPI is held constant and an ac transformer tap is adjusted to control dc voltage (i.e., when IFI, ITI, and IDI specify a transformer branch). DCVMIN = 0. by default.
CCCITMX	Iteration limit for capacitor commutated two-terminal dc line Newton solution procedure. CCCITMX = 20 by default.
CCCACC	Acceleration factor for capacitor commutated two-terminal dc line Newton solution procedure. CCCACC = 1.0 by default.

The second of the three dc line data records defines rectifier end data quantities and control parameters:

IPR	Rectifier converter bus number, or extended bus name enclosed in single quotes (see Section 4.1.2). No default allowed.
NBR	Number of bridges in series (rectifier). No default allowed.
ALFMX	Nominal maximum rectifier firing angle; entered in degrees. No default allowed.
ALFMN	Minimum steady-state rectifier firing angle; entered in degrees. No default allowed.
RCR	Rectifier commutating transformer resistance per bridge; entered in ohms. No default allowed.
XCR	Rectifier commutating transformer reactance per bridge; entered in ohms. No default allowed.
EBASR	Rectifier primary base ac voltage; entered in kV. No default allowed.
TRR	Rectifier transformer ratio. TRR = 1. by default.
TAPR	Rectifier tap setting. TAPR = 1. by default.
TMXR	Maximum rectifier tap setting. TMXR = 1.5 by default.
TMNR	Minimum rectifier tap setting. TMNR = 0.51 by default.
STPR	Rectifier tap step; must be positive. STPR = 0.00625 by default.

ICR	Rectifier firing angle measuring bus number, or extended bus name enclosed in single quotes (see Section 4.1.2). The firing angle and angle limits used inside the dc model are adjusted by the difference between the phase angles at this bus and the ac/dc interface (i.e., the converter bus, IPR). ICR = 0 by default.
IFR	Tapped side " <i>from bus</i> " number, or extended bus name enclosed in single quotes (see Section 4.1.2), of an ac transformer branch. IFR = 0 by default.
ITR	Untapped side " <i>to bus</i> " number, or extended bus name enclosed in single quotes (see Section 4.1.2), of an ac transformer branch. ITR = 0 by default.
IDR	Circuit identifier; the branch described by IFR, ITR, and IDR must have been entered as a transformer branch; an ac transformer may control at most only one dc converter. IDR = '1' by default. If no branch is specified, TAPR is adjusted to keep alpha within limits; otherwise, TAPR is held fixed and this transformer's tap ratio is adjusted. The adjustment logic assumes that the rectifier converter bus is on the untapped side of the transformer. The limits TMXR and TMNR specified here are used; except for the transformer adjustment enable flag (see Section 4.1.1.6), the ac tap adjustment data is ignored.
XCAPR	Commutating capacitor reactance magnitude per bridge; entered in ohms. XCAPR = 0.0 by default.

Data on the third of the three dc line data records contains the inverter quantities corresponding to the rectifier quantities specified on the second record described above.

The dc line converter buses, IPR and IPI, may be type one, two, or three buses. Generators, loads, and shunt elements are permitted at converter buses.

When either XCAPR > 0.0, or XCAPI > 0.0, the two-terminal dc line is treated as capacitor commutated. Capacitor commutated two-terminal dc lines preclude the use of a remote ac transformer as commutation transformer tap and remote commutation angle buses at either converter. Any data provided in these fields are ignored for capacitor commutated two-terminal dc lines.

The dc line data input is terminated with a record specifying a dc line number of zero.

4.1.1.9 Switched Shunt Data

Each network bus to be represented in PSS/E with switched shunt admittance devices must have a switched shunt data record specified for it. The switched shunts are represented with up to eight blocks of admittance, each one of which consists of up to nine steps of the specified block admittance. Each switched shunt data record has the following format:

I, MODSW, VSWHI, VSWLO, SWREM, BINIT, N₁, B₁, N₂, B₂, ... N₈, B₈

where:

I Bus number (1 to 99997), or extended bus name enclosed in single quotes (see [Section 4.1.2](#)).

MODSW	Control mode: 0 - fixed 1 - discrete 2 - continuous MODSW = 1 by default.
VSWHI	Desired voltage upper limit; entered in pu. VSWHI = 1. by default.
VSWLO	Desired voltage lower limit; entered in pu. VSWLO = 1. by default.
SWREM	Bus number, or extended bus name enclosed in single quotes (see Section 4.1.2), of a remote <i>type one</i> bus whose voltage is to be regulated by this switched shunt to the voltage range specified by VSWHI and VSWLO. SWREM is entered as zero if the device is to regulate its own voltage. SWREM = 0 by default.
BINIT	Initial switched shunt admittance; entered in Mvar at unity voltage. BINIT = 0. by default.
N_i	Number of steps for block i . The first zero value of N_i or B_i is interpreted as the end of the switched shunt blocks for bus I . $N_i = 0$ by default.
B_i	Admittance increment for each of N_i steps in block i ; entered in Mvar at unity voltage. $B_i = 0$. by default.

BINIT needs to be set to its actual solved case value only when the network, as entered into the working case via activity READ, is to be considered solved as read in, or when the device is to be treated as "fixed" (i.e., MODSW is set to zero or switched shunts are to be locked during power flow solutions).

The switched shunt elements at a bus may consist entirely of reactors (each B_i is a negative quantity) or entirely of capacitor banks (each B_i is a positive quantity). In these cases, the shunt blocks are specified in the order in which they are switched on the bus.

If the switched shunt devices at a bus are a mixture of reactors and capacitors, the reactor blocks are specified first in the order in which they are switched on, followed by the capacitor blocks in the order in which they are switched on.

The switched shunt admittance is kept in the working case and reported in output tabulations separately from the bus shunt, which is input on the bus data record.

Refer to [Section 4.8.4](#) for details on the handling of switched shunts during the power flow solution activities.

Switched shunt data input is terminated with a record specifying a bus number of zero.

4.1.1.10 Transformer Impedance Correction Tables

Transformer impedance correction tables are used to model a change of transformer impedance as off-nominal turns ratio or phase shift angle is adjusted. Data for each table may be specified either at the time of raw data input or subsequently via activity **CHNG** or the impedance correction table data editor window. Each transformer impedance correction data record has the following format:

$$I, T_1, F_1, T_2, F_2, T_3, F_3, \dots, T_{11}, F_{11}$$

where:

- I Impedance correction table number.
- T_i Either off-nominal turns ratio in pu or phase shift angle in degrees. $T_i = 0$. by default.
- F_i Scaling factor by which transformer nominal impedance is to be multiplied to obtain the actual transformer impedance for the corresponding " T_i ". $F_i = 0$. by default.

The " T_i " values on a transformer impedance correction table record must all be either tap ratios or phase shift angles. They must be entered in strictly ascending order; i.e., for each "i", $T_{i+1} > T_i$. Each " F_i " entered must be greater than zero. On each record, at least 2 pairs of values must be specified and up to 11 may be entered.

A transformer is assigned to an impedance correction table either on the transformer adjustment data record of activities READ, **TREA**, **RDCH** (see Section 4.1.1.6), or via activities **CHNG** or **XLIS**, or the data editor windows. Each table may be shared among many transformers. If the first "T" in a table is less than 0.5 or the last "T" entered is greater than 1.5, "T" is assumed to be the phase shift angle and the impedance of each transformer assigned to the table is treated as a function of phase shift angle. Otherwise, the impedances of the transformers assigned to the table are made sensitive to off-nominal turns ratio.

The working case provides for the storage of both a nominal and actual impedance for each transformer. The value of transformer impedance entered in activities READ, **TREA**, **RDCH**, **CHNG**, or **XLIS**, and in the data editor windows is taken as the nominal value of impedance. Each time the complex tap ratio of a transformer is changed, either automatically by the power flow solution activities or manually by the user, and the transformer has been assigned to an impedance correction table, actual transformer impedance is redetermined if appropriate. First, the scaling factor is established from the appropriate table by linear interpolation; then nominal impedance is multiplied by the scaling factor to determine actual impedance. An appropriate message is printed any time the actual impedance is modified.

Transformer impedance correction data input is terminated with a record specifying a table number of zero.

4.1.1.11 Multiterminal dc Transmission Line Data

Each multiterminal dc transmission line to be represented in PSS/E is introduced by reading a series of data records. Each set of multiterminal dc line data records begins with a record of the following format:

I, NCONV, NDCBS, NDCLN, MDC, VCONV, VCMOD, VCONVN

where:

I	Multiterminal dc line number.
NCONV	Number of ac converter station buses in multiterminal dc line "I". No default allowed.
NDCBS	Number of "dc buses" in multiterminal dc line "I" ($NCONV \leq NDCBS$). No default allowed.
NDCLN	Number of dc links in multiterminal dc line "I". No default allowed.
MDC	Control mode: 0 - blocked 1 - power 2 - current MDC = 0 by default.
VCONV	Bus number, or extended bus name enclosed in single quotes (see Section 4.1.2), of the ac converter station bus that controls dc voltage on the positive pole of multiterminal dc line "I". Bus VCONV must be a positive pole inverter. No default allowed.
VCMOD	Mode switch dc voltage; entered in kV. When any inverter dc voltage magnitude falls below this value and the line is in power control mode (i.e., MDC = 1), the line switches to current control mode with converter current setpoints corresponding to their desired powers at scheduled dc voltage. VCMOD = 0. by default.
VCONVN	Bus number, or extended bus name enclosed in single quotes (see Section 4.1.2), of the ac converter station bus that controls dc voltage on the negative pole of multiterminal dc line "I". If any negative pole converters are specified (see below), bus VCONVN must be a negative pole inverter. If the negative pole is not being modeled, VCONVN must be specified as zero. VCONVN = 0 by default.

This data record is followed by "NCONV" converter records of the following format:

IB, N, ANGMX, ANGMN, RC, XC, EBAS, TR, TAP, TPMX, TPMN, TSTP, SETVL, DCPF, MARG, CNVCOD

where:

IB	Is the ac converter bus number, or extended bus name enclosed in single quotes (see Section 4.1.2). No default allowed.
----	--

N	Number of bridges in series. No default allowed.
ANGMX	Nominal maximum ALPHA or GAMMA angle; entered in degrees. No default allowed.
ANGMN	Minimum steady-state ALPHA or GAMMA angle; entered in degrees. No default allowed.
RC	Commutating resistance per bridge; entered in ohms. No default allowed.
XC	Commutating reactance per bridge; entered in ohms. No default allowed.
EBAS	Primary base ac voltage; entered in kV. No default allowed.
TR	Actual transformer ratio. TR = 1.0 by default.
TAP	Tap setting. TAP = 1.0 by default.
TPMX	Maximum tap setting. TPMX = 1.5 by default.
TPMN	Minimum tap setting. TPMN = 0.51 by default.
TSTP	Tap step; must be positive. TSTP = 0.00625 by default.
SETVL	Converter setpoint. When IB is equal to VCONV or VCONVN, SETVL specifies the scheduled dc voltage magnitude, entered in kV, across the converter. For other converter buses, SETVL contains the converter current (amps) or power (MW) demand; a positive value of SETVL indicates that bus IB is a rectifier, and a negative value indicates an inverter. No default allowed.
DCPF	<p>Converter "participation factor." When the order at any rectifier in the multi-terminal dc line is reduced, either to maximum current or margin, the orders at the remaining converters on the same pole are modified according to their DCPFs to:</p> $\text{SETVL} + (\text{DCPF}/\text{SUM}) * \text{R}$ <p>where SUM is the sum of the DCPFs at the unconstrained converters on the same pole as the constrained rectifier, and R is the order reduction at the constrained rectifier. DCPF = 1. by default.</p>
MARG	Rectifier margin entered in per unit of desired dc power or current. The converter order reduced by this fraction, (1.-MARG)*SETVL, defines the minimum order for this rectifier. MARG is used only at rectifiers. MARG = 0. by default.
CNVCOD	Converter code. A positive value or zero must be entered if the converter is on the positive pole of multiterminal dc line "I". A negative value must be entered for negative pole converters. CNVCOD = 1 by default.

These data records are followed by "NDCBS" dc bus records of the following format:

IDC, IB, IA, ZONE, 'NAME', IDC2, RGRND, OWNER

where:

IDC	Is the dc bus number (1 to NDCBS). The dc buses are used internally within each multiterminal dc line and must be numbered 1 through NDCBS. No default allowed.
IB	Is the ac converter bus number, or extended bus name enclosed in single quotes (see Section 4.1.2), or zero. Each converter station bus specified in a converter record must be specified as IB in exactly one dc bus record. The dc buses that are connected only to other dc buses by dc links and not to any ac converter buses must have a zero specified for IB. A dc bus specified as IDC2 on one or more other dc bus records must have a zero specified for IB on its own dc bus record. IB = 0 by default.
IA	Area number. IA = 1 by default.
ZONE	Zone number. ZONE = 1 by default.
NAME	Alphanumeric identifier assigned to dc bus "IDC". The name may be up to eight characters and must be enclosed in single quotes. NAME may contain any combination of blanks, uppercase letters, numbers, and special characters. NAME is eight blanks by default.
IDC2	Second dc bus to which converter IB is connected, or zero if the converter is connected directly to ground. For voltage controlling converters, this is the dc bus with the lower dc voltage magnitude and SETVL specifies the voltage difference between buses IDC and IDC2. For rectifiers, dc buses should be specified such that power flows from bus IDC2 to bus IDC. For inverters, dc buses should be specified such that power flows from bus IDC to bus IDC2. IDC2 is ignored on those dc bus records that have IB specified as zero. IDC2 = 0 by default.
RGRND	Resistance to ground at dc bus IDC; entered in ohms. During solutions RGRND is used only for those dc buses specified as IDC2 on other dc bus records. RGRND = 0. by default.
OWNER	Owner number. OWNER = 1 by default.

These data records are followed by "NDCLN" dc link records of the following format:

IDC, JDC, DCCKT, RDC, LDC

where:

IDC	Branch " <i>from bus</i> " dc bus number.
JDC	Branch " <i>to bus</i> " dc bus number. JDC is entered as a negative number to designate it as the metered end for area and zone interchange calculations. Otherwise, bus IDC is assumed to be the metered end.
DCCKT	One-character uppercase alphanumeric branch circuit identifier. It is strongly recommended that single circuit branches be designated as having the circuit identifier '1'. DCCKT = '1' by default.

RDC	Is the dc link resistance, entered in ohms. No default allowed.
LDC	Is the dc link inductance, entered in mH. LDC is not used by the power flow solution activities but is available to multiterminal dc line dynamics models. LDC = 0. by default.

The following points should be noted in specifying multiterminal dc line data:

1. Two-terminal (see [Section 4.1.1.8](#)) and multiterminal dc lines are stored separately in PSS/E working memory. Therefore, there may simultaneously exist, for example, a two-terminal dc line identified as dc line number 1 along with a multiterminal line numbered 1.
2. Multiterminal lines should have at least three converter terminals; dc lines consisting of two terminals should be modeled as two-terminal lines (see [Section 4.1.1.8](#)).
3. The ac converter buses may be type one, two, or three buses. Generators, loads, and shunt elements are permitted at converter buses.
4. Each multiterminal dc line is treated as a subnetwork of "dc buses" and "dc links" connecting its ac converter buses. For each multiterminal dc line, the dc buses must be numbered 1 through NDCBS.
5. Each ac converter bus must be specified as IB on one and only one dc bus record; there may be dc buses connected only to other dc buses by dc links but not to any ac converter bus.
6. An ac converter bus "IB" may be connected to a dc bus "IDC", which is connected directly to ground. "IB" is specified on the dc bus record for dc bus "IDC"; the IDC2 field is specified as zero.
7. Alternatively, an ac converter bus "IB" may be connected to two dc buses "IDC" and "IDC2", the second of which is connected to ground through a specified resistance. "IB" and "IDC2" are specified on the dc bus record for dc bus "IDC"; on the dc bus record for bus "IDC2", the ac converter bus and second dc bus fields (IB and IDC2, respectively) must be specified as zero and the grounding resistance is specified as RGRND.
8. The same dc bus may be specified as the second dc bus for more than one ac converter bus.
9. All dc buses within a multiterminal dc line must be reachable from any other point within the subnetwork.
10. The area number assigned to dc buses and the metered end designation of dc links are used in calculating area interchange and assigning losses in activities [AREA](#), [INTA](#), [TIES](#), and [SUBS](#) as well as in the interchange control option of the power flow solution activities. Similarly, the zone assignment and metered end specification is used in activities [ZONE](#), [INTZ](#), [TIEZ](#), and [SUBS](#).

Multiterminal dc line data input is terminated with a record specifying a dc line number of zero.

4.1.1.12 Multisection Line Grouping Data

Each multisection line grouping to be represented in PSS/E is introduced by reading a multisection line grouping data record. Each multisection line grouping data record has the following format:

I, J, ID, CKT₁, DUM₁, CKT₂, DUM₂, ... CKT₉, DUM₉, CKT₁₀

where:

- I *"From bus"* number, or extended bus name enclosed in single quotes (see [Section 4.1.2](#)).
- J *"To bus"* number, or extended bus name enclosed in single quotes (see [Section 4.1.2](#)). J is entered as a negative number or with a minus sign before the first character of the extended bus name to designate it as the metered end; otherwise, bus I is assumed to be the metered end.
- ID Two-character multisection line grouping identifier. The first character **must** be an ampersand ("&"). ID = '&1' by default.
- CKT_i Branch circuit identifiers of branches that are members of this multisection line grouping. CKT_i = '1' by default.
- DUM_i Bus numbers, or extended bus name enclosed in single quotes (see [Section 4.1.2](#)), of the "dummy buses" connected by the branches that comprise this multisection line grouping. No defaults allowed.

The "CKT_i" and "DUM_i" values on each record define the branches connecting bus I to bus J, and are entered so as to trace the path from bus I to bus J. Specifically, for a multisection line grouping consisting of three "line sections" (and hence two "dummy buses"):

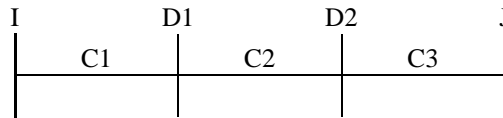

The path from "I" to "J" is defined by the following branches:

From	To	Circuit
I	D1	C1
D1	D2	C2
D2	J	C3

If this multisection line grouping is to be assigned the line identifier "&1", the corresponding multisection line grouping data record is given by:

I J &1 C1 D1 C2 D2 C3

Up to 10 line sections (and hence 9 dummy buses) may be defined in each multisection line grouping. A branch may be a line section of at most one multisection line grouping.

Each dummy bus must have exactly two branches connected to it, both of which must be members of the same multisection line grouping. A multisection line dummy bus may not be a converter bus of a dc transmission line. A FACTS control device may not be connected to a multisection line dummy bus.

The status of line sections and type codes of dummy buses are set such that the multisection line is treated as a single entity with regards to its service status.

When the multisection line reporting option is enabled (see [Sections 3.11](#) and [6.10](#)), several power flow reporting activities such as **POUT** and **LOUT** do not tabulate conditions at multisection line dummy buses. Accordingly, care must be taken in interpreting power flow output reports if load and/or generation is present at such buses.

Multisection line grouping data input is terminated with a record specifying a "from bus" number of zero.

4.1.1.13 Zone Data

Zone identifiers are specified in zone data records. Data for each zone may be specified either at the time of raw data input or subsequently via activities **CHNG** or **XLIS**, or the data editor windows. Each zone data record has the following format:

```
I, 'ZONAME'
```

where:

I Zone number.

ZONAME Alphanumeric identifier assigned to zone I. The name may contain up to eight characters and **must** be enclosed in single quotes. ZONAME may be any combination of blanks, uppercase letters, numbers, and special characters. ZONAME is set to eight blanks by default.

Zone data input is terminated with a record specifying a zone number of zero.

4.1.1.14 Interarea Transfer Data

Real power transfers between pairs of areas are specified in interarea transfer data records. Each interarea transfer data record has the following format:

```
ARFROM, ARTO, TRID, PTRAN
```

where:

ARFROM "From area" number (seller).

ARTO "To area" number (buyer).

TRID Single-character (0 through 9 or A through Z) interarea transfer identifier used to distinguish among multiple transfers between areas ARFROM and ARTO. TRID = '1' by default.

PTRAN MW comprising this transfer. A positive PTRAN indicates that area ARFROM is selling to area ARTO. PTRAN = 0. by default.

Following the completion of interarea transfer data input, activity READ alarms any area for which at least one interarea transfer is present and whose "sum of transfers" differs from its desired net interchange, PDES (see [Section 4.1.1.7](#)).

Interarea transfer data input is terminated with a record specifying a from area number of zero.

4.1.1.15 Owner Data

Owner identifiers are specified in owner data records. Data for each owner may be specified either at the time of raw data input or subsequently via activities **CHNG** or **XLIS**, or the data editor windows. Each owner data record has the following format:

```
I, 'OWNAME'
```

where:

I Owner number.

OWNAME Alphanumeric identifier assigned to owner I. The name may contain up to eight characters and must be enclosed in single quotes. OWNAME may be any combination of blanks, uppercase letters, numbers, and special characters. OWNAME is set to eight blanks by default.

Owner data input is terminated with a record specifying an owner number of zero.

4.1.1.16 FACTS Control Device Data

Each FACTS (Flexible AC Transmission System) control device to be represented in PSS/E is specified in FACTS control device data records. Each FACTS device data record has the following format:

```
N, I, J, MODE, PDES, QDES, VSET, SHMX, TRMX, VTMN, VTMX, VSMX, IMX, LINX, OWNER
```

where:

N FACTS device number.

I Sending end bus number. No default allowed.

J Terminal end bus number; 0 for a STATCON. J = 0 by default.

MODE Control mode:
 0 - out-of-service (i.e., series and shunt links open)
 1 - series and shunt links operating
 2 - series link bypassed (i.e., like a zero impedance line) and shunt link operating as a STATCON
 MODE = 1 by default.

PDES Desired real power flow arriving at the terminal end bus; entered in MW.
 PDES = 0. by default.

QDES	Desired reactive power flow arriving at the terminal end bus; entered in MVAR. QDES = 0. by default.
VSET	Voltage setpoint at the sending end bus; entered in pu. VSET = 1.0 by default.
SHMX	Maximum shunt current at the sending end bus; entered in MVA at unity voltage. SHMX = 9999. by default.
TRMX	Maximum bridge real power transfer; entered in MW. TRMX = 9999. by default.
VTMN	Minimum voltage at the terminal end bus; entered in pu. VTMN = 0.9 by default.
VTMX	Maximum voltage at the terminal end bus; entered in pu. VTMX = 1.1 by default.
VSMX	Maximum series voltage; entered in pu. VSMX = 1.0 by default.
IMX	Maximum series current, or zero for no series current limit; entered in MVA at unity voltage. IMX = 0. by default.
LINX	Reactance of the dummy series element used in certain model solution states; entered in pu. LINX = 0.05 by default.
OWNER	Owner number. OWNER = 1 by default.

Figure 4-2 shows the PSS/E FACTS control device model with its various setpoints and limits.

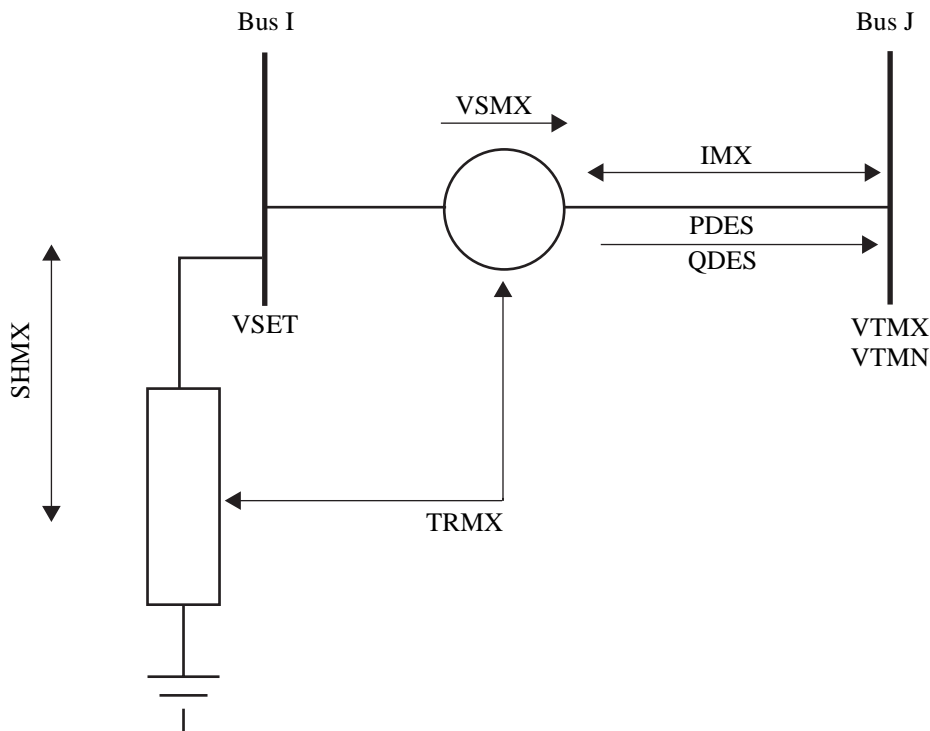

Figure 4-2. FACTS Control Device Setpoints and Limits